

Sestava 2x 12NDL76 + BMS4590 + ME60:

Osazení:

- 2x B&C Speakers 12NDL76

<http://eshop.prodance.cz/12ndl76-8-ohm/d-82724/>

- BMS BMS4590

<http://eshop.prodance.cz/bms4590-8-ohm/d-87230/>

- B&C Speakers ME60

<http://eshop.prodance.cz/me60/d-80243/>

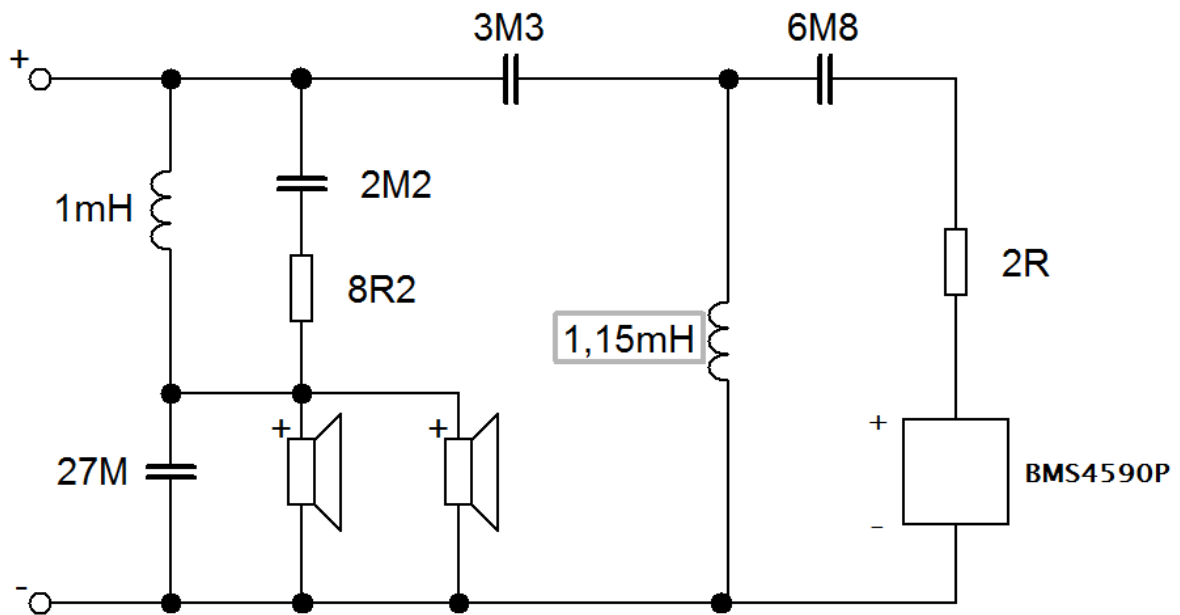

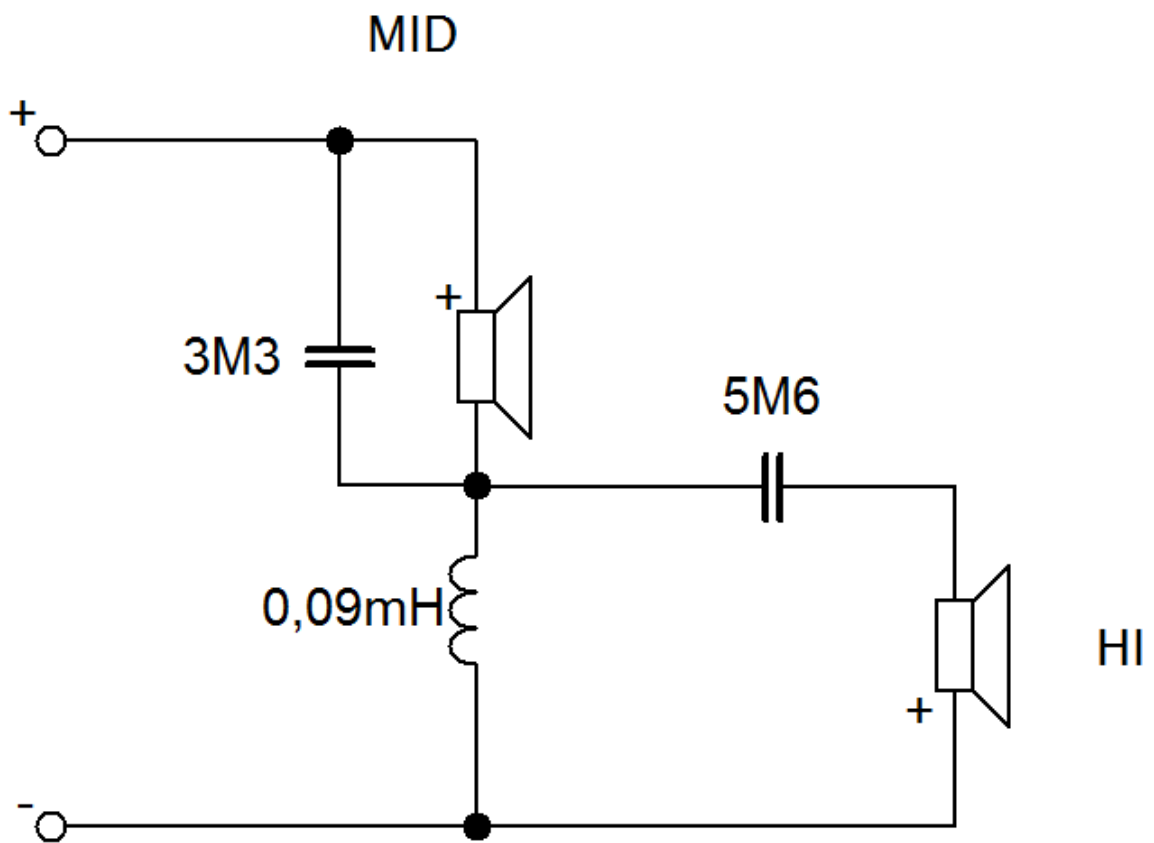
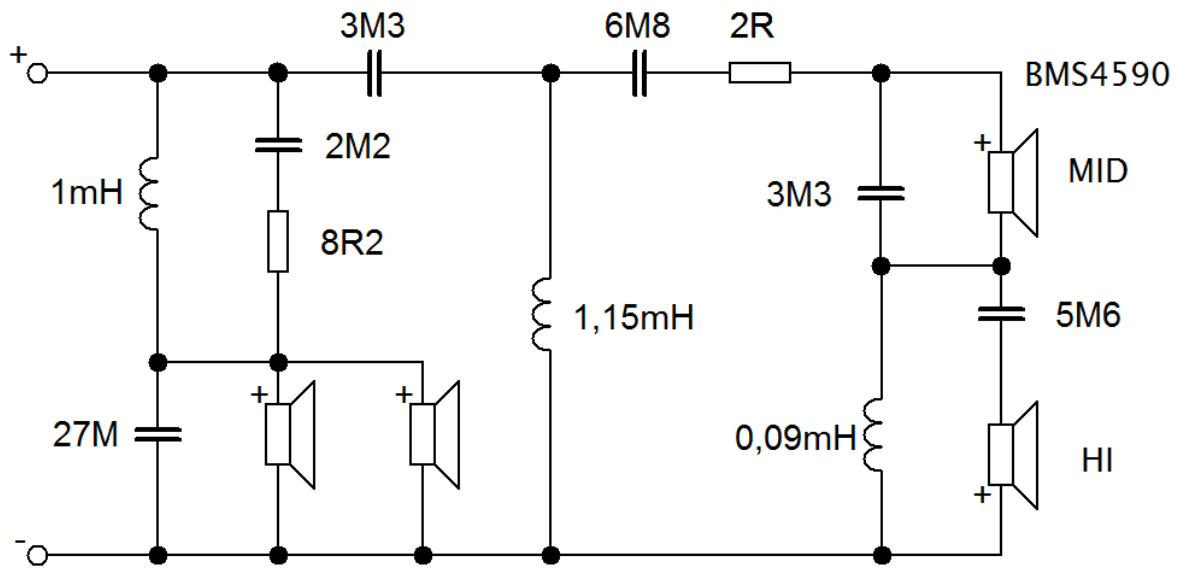

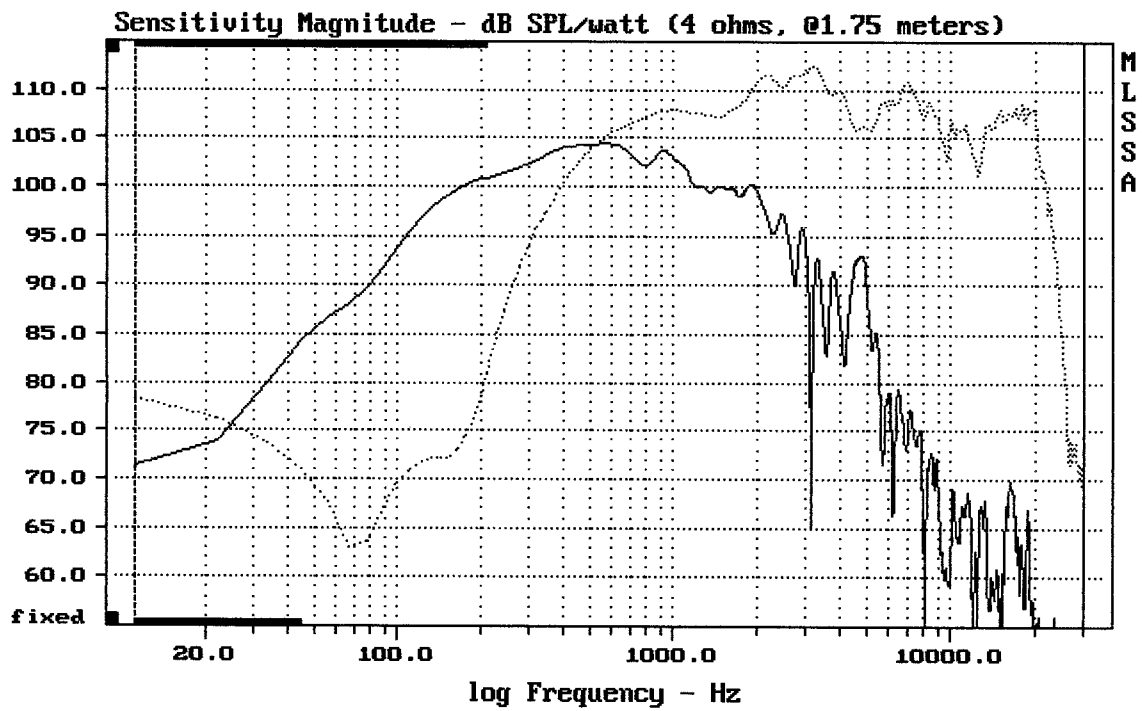

CURSOR: dy = 20.5142 x = 30007.1014 (2704)

2x12NDL76 + BMS4590 + ME60

MLSSA: Frequency Domain

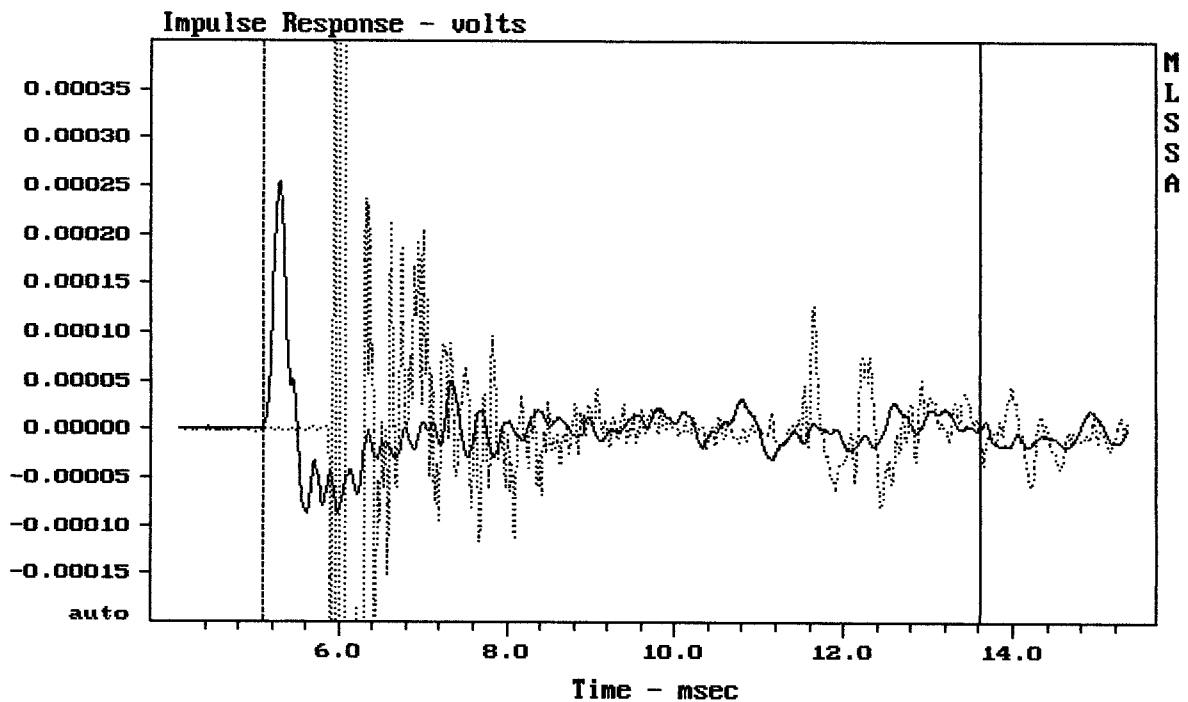

mean: 4.802e-007, rms: 0.0002165, std: 0.0002165, max: 0.002061, min: -0.001941

2x12NDL76 + BMS4590 + ME60

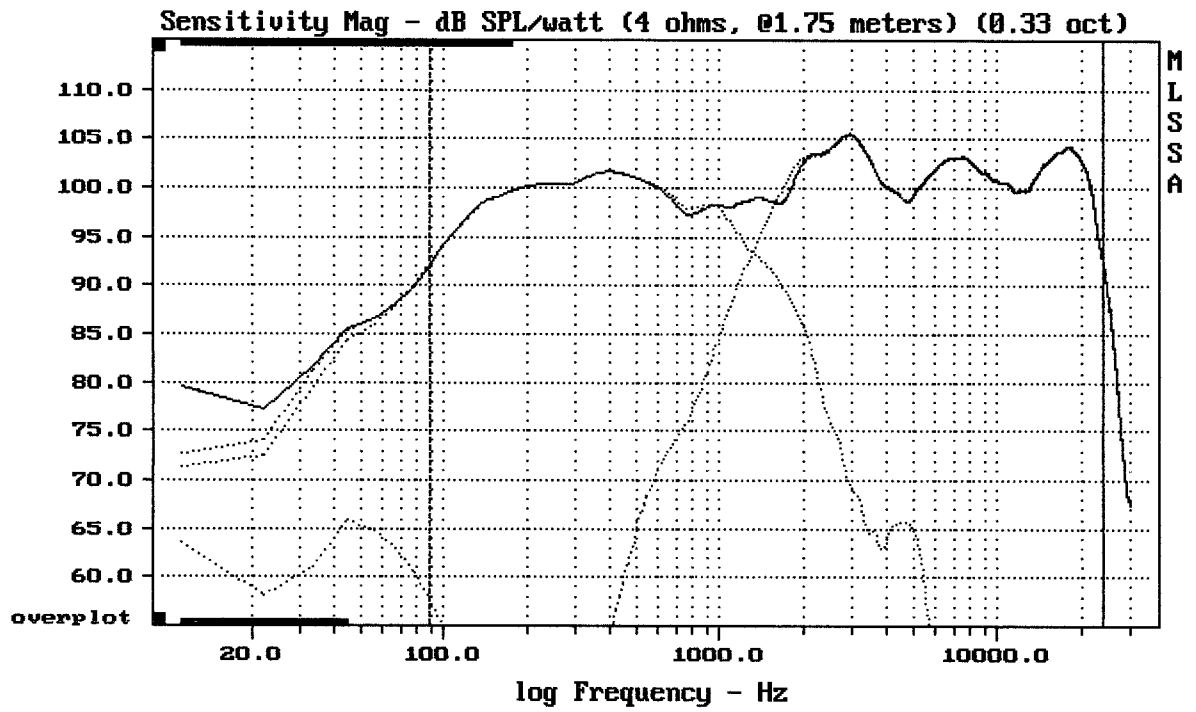

Level (89:23904 Hz) = 100.96 dB SPL/watt (4 ohms, @1.75 meters) (0.33 oct)

2x12NDL76 + BMS4590 + ME60

MLSSA: Frequency Domain

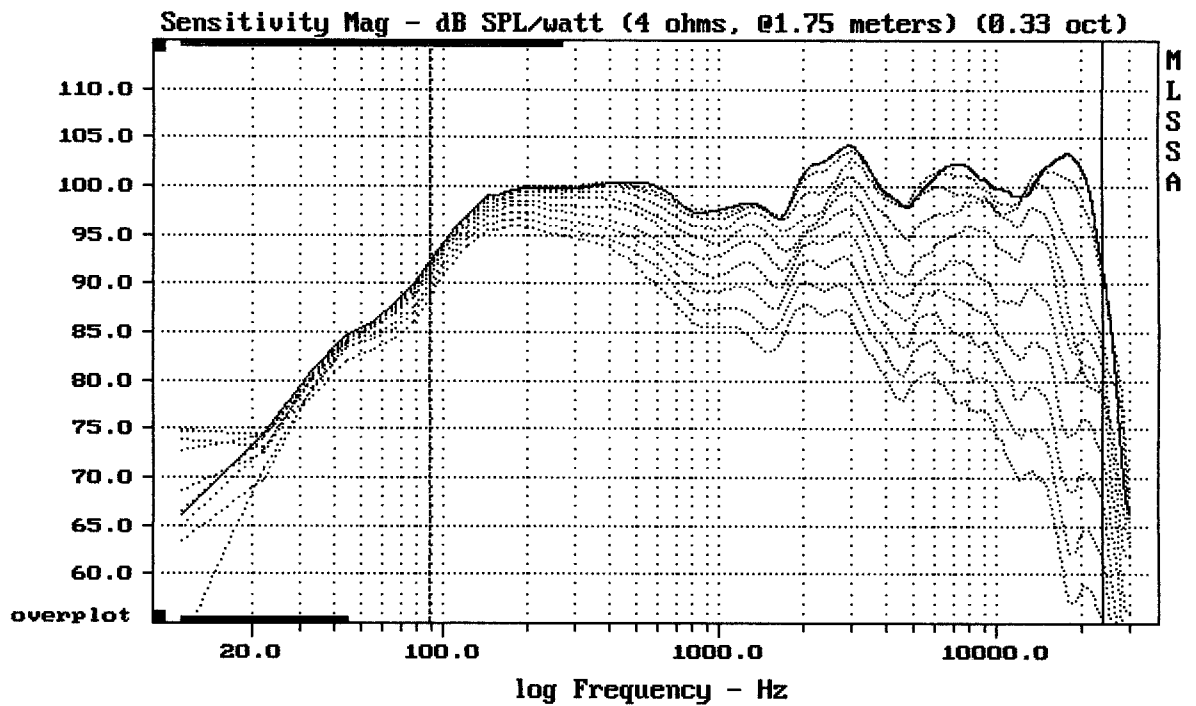

Overlay Compare: dev= +26/-17, std= 11, avg= -29

2x12NDL76 + BMS4590 + ME60

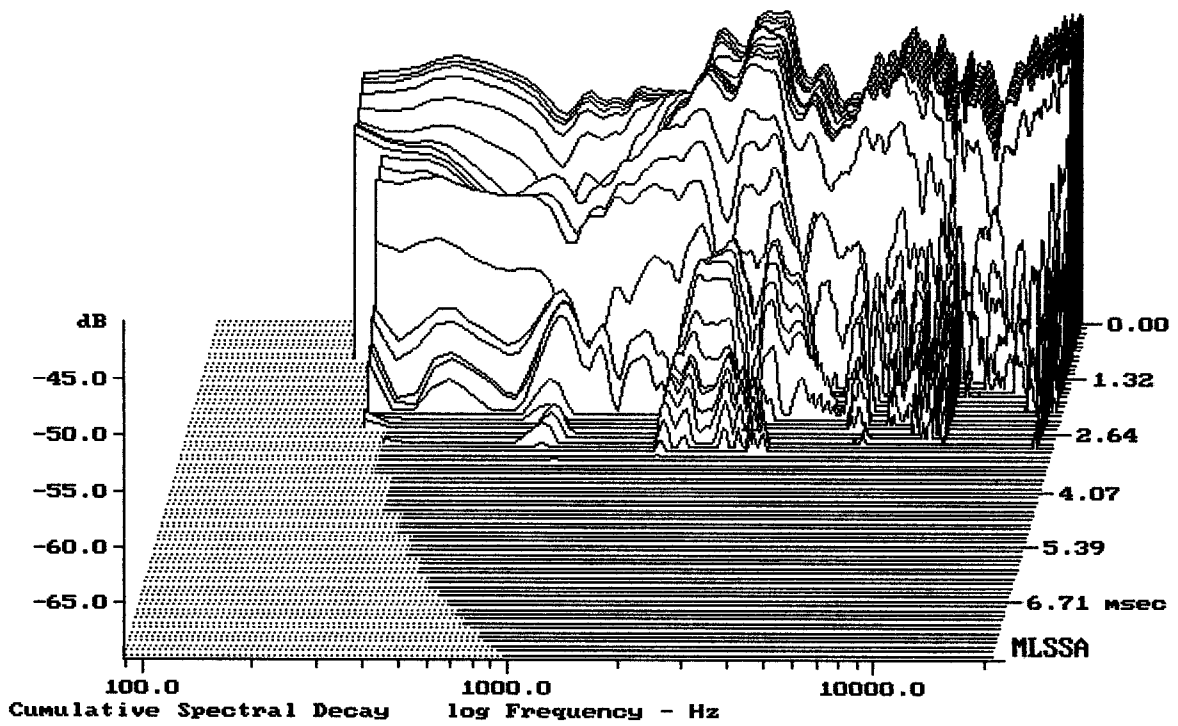

-68.08 dB, 3196 Hz (72), 3.080 msec (29)

DTTO

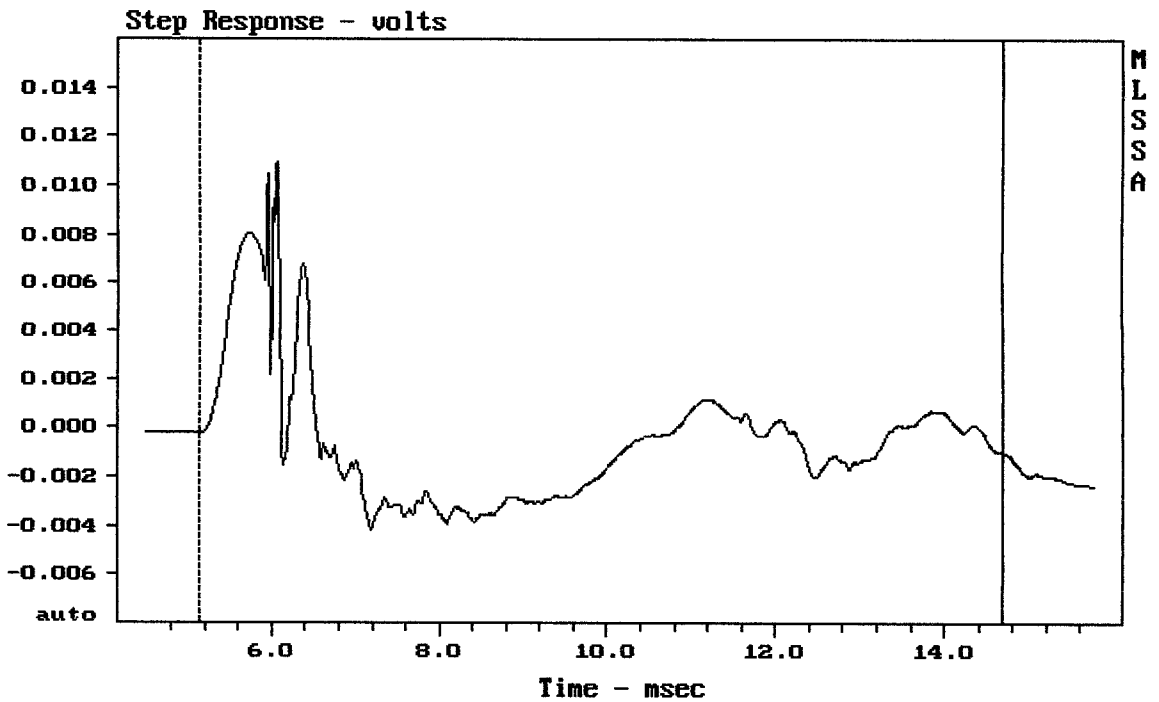

mean: -0.0005249, rms: 0.002803, std: 0.002753, max: 0.01091, min: -0.004206

2x12NDL76 + BMS4590 + ME60

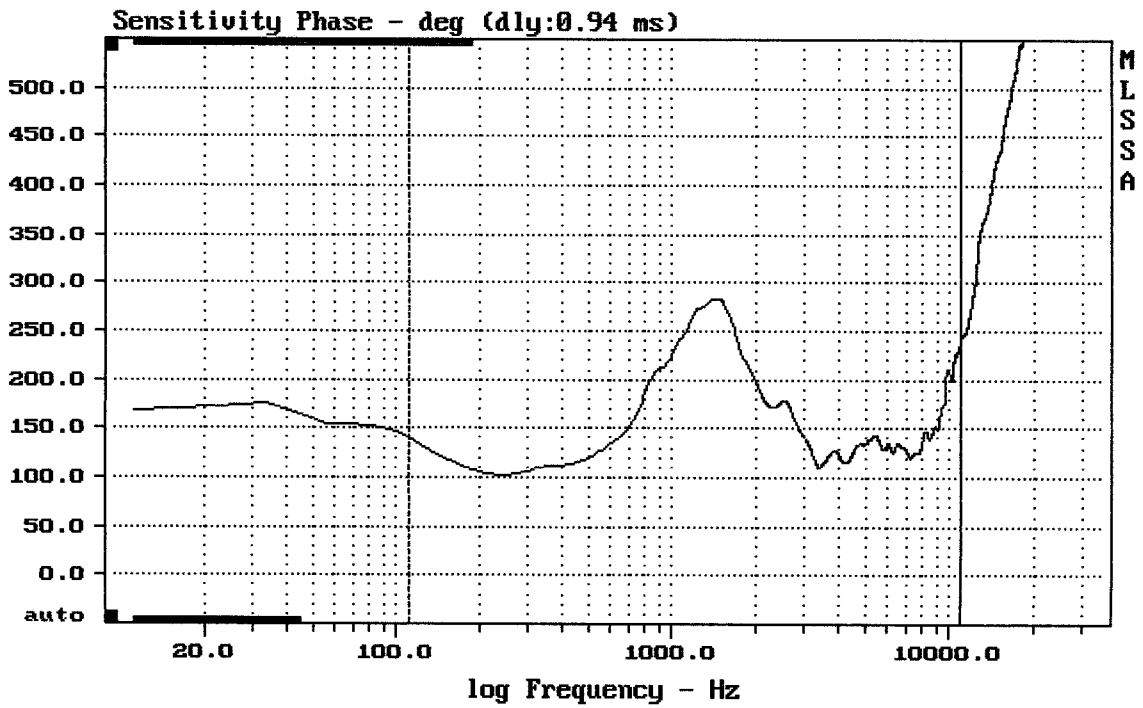

mean: 159.2, rms: 165.1, std: 44, max: 283.8, min: 102.1

2x12NDL76 + BMS4590 + ME60

MLSSA: Frequency Domain

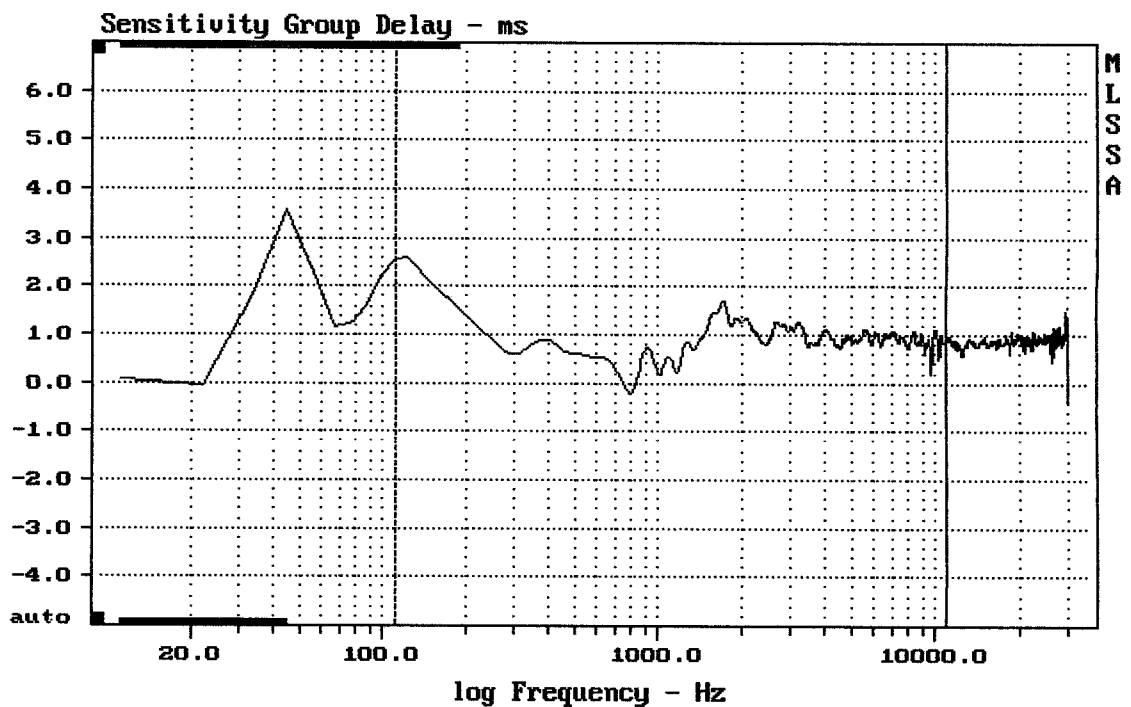

mean: 0.9201, rms: 0.9587, std: 0.2693, max: 2.581, min: -0.214

2x12NDL76 + BMS4590 + ME60

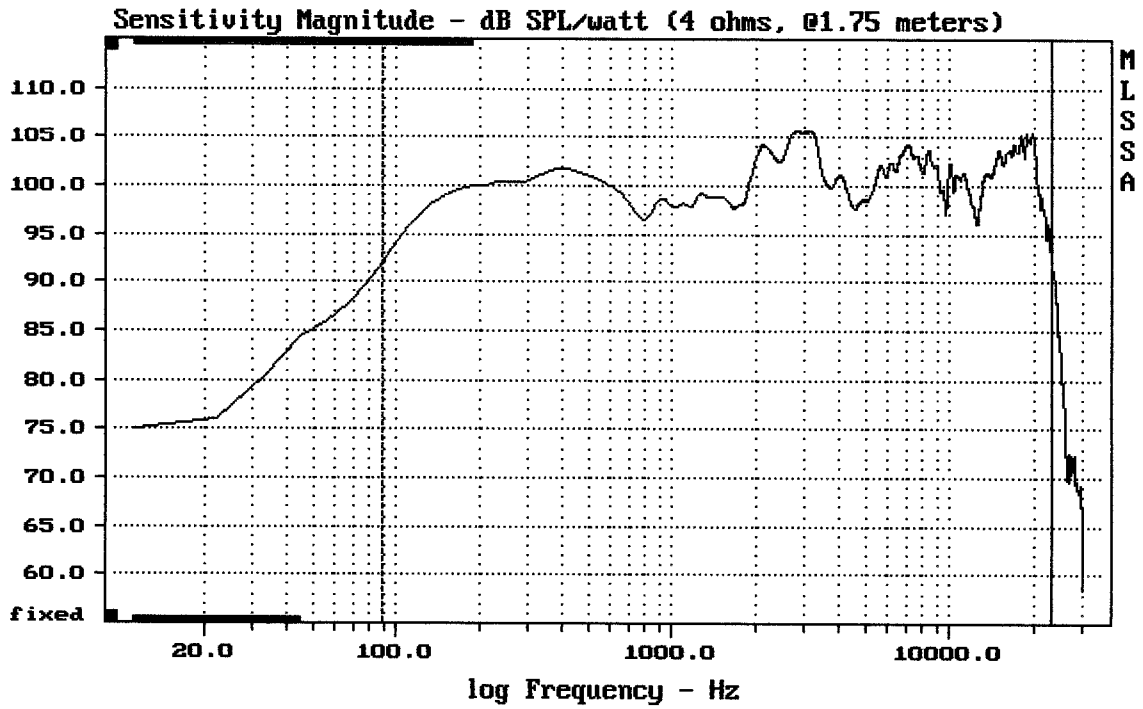

mean: 101.56, rms: 101.92, std: 2.25, max: 105.70, min: 92.06

2x12NDL76 + BMS4590 + ME60

MLSSA: Frequency Domain

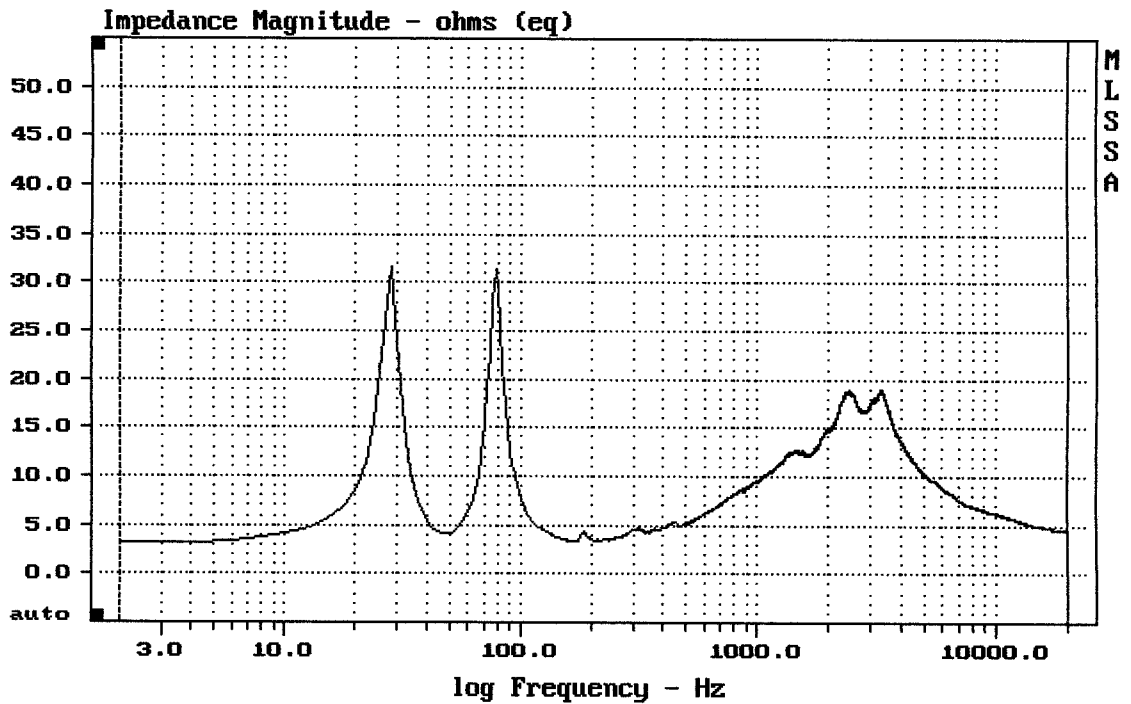

mean: 7.678, rms: 8.617, std: 3.913, max: 31.64, min: 3.178

2x12NDL76 + BMS4590 + ME60